

**THE L290/L291/L292 DC MOTOR
SPEED/POSITION CONTROL SYSTEM**

The L290, L291 and L292 together form a complete microprocessor-controlled DC motor servopositioning system that is both fast and accurate. This design guide presents a description of the system, detailed function descriptions of each device and application information.

The L290, L291 and L292 are primarily intended for use with a DC motor and optical encoder in the configuration shown schematically in figure 1. This system is controlled by a microprocessor, or microcomputer, which determines the optimum speed profile for each movement and passes appropriate commands to the L291, which contains the system's D/A converter and error amplifiers. the

L291 generates a voltage control signal to drive the L292 switchmode driver which powers the motor. An optical encoder on the motor shaft provides signals which are processed by the L290 tachometer converter to produce tacho voltage feedback and position feedback signals for the L291 plus distance/direction feedback signals for the control micro.

Figure 1 : The L290, L291 and L292 form a complete DC Motor servopositioning System that connects directly to Microcomputer Chips.

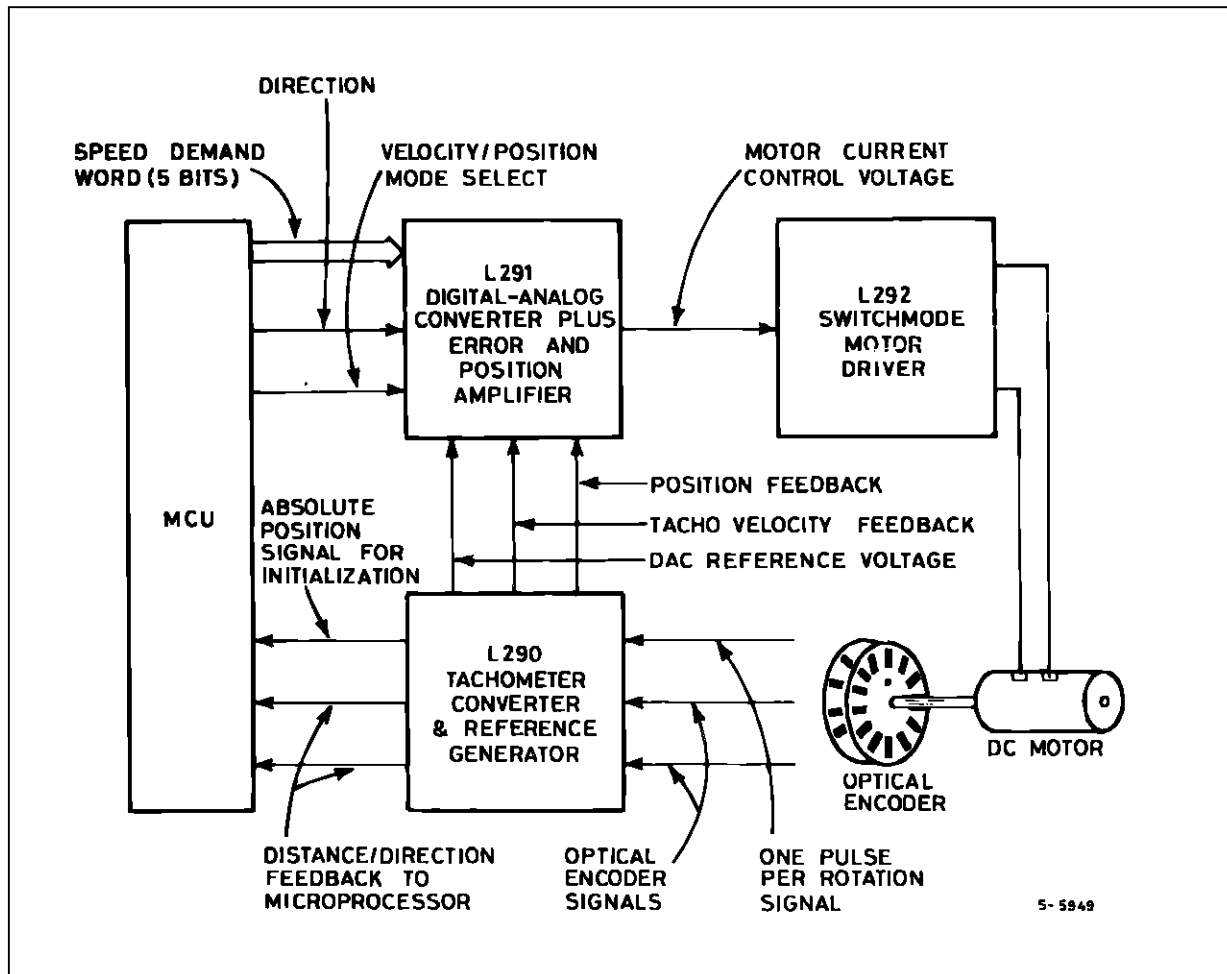

APPLICATION NOTE

The system operates in two modes to achieve high speed and accuracy: closed loop speed control and closed loop position control. The combination of these two modes allows the system to travel rapidly towards the target position then stop precisely without ringing.

Initially the system operates in speed control mode. A movement begins when the microcomputer applies a speed demand word to the L291, typically calling for maximum speed. At this instant the motor speed is zero so there is no tacho feedback and the system operates effectively in open loop mode (see figure 2). In this condition a high current peak - up to 2A - accelerates the motor rapidly to ensure a fast start.

As the motor accelerates the tacho voltage rises and the system operates in closed loop speed mode, moving rapidly towards the target position. The microcomputer, which is monitoring the optical encoder signals (squared by the L290), reduces the speed demand word gradually when the target position is close. Each time the speed demand word is reduced the motor is braked by the speed control loop.

Finally, when the speed code is zero and the target position extremely close, the micro commands the system to switch to position mode. The motor then stops rapidly at the desired position and is held in an electronic detent.

Figure 2 : The System operates in two Modes to achieve High Speed and Accuracy. Tachometer Feedback regulates the Speed during a Run and brakes the Motor towards the End. Position Feedback allows a Precise Final Positioning.

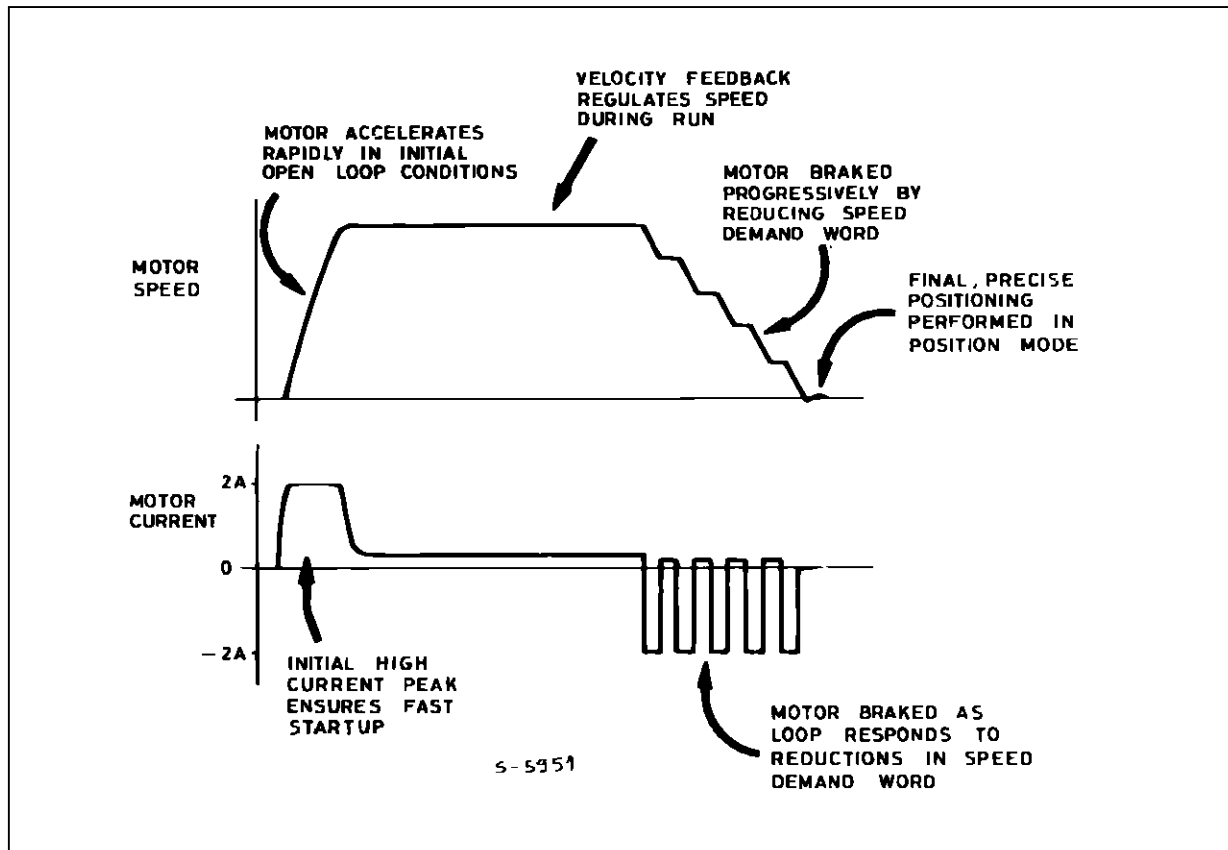

OPTICAL ENCODER

The optical encoder used in this system is shown schematically in figure 3. It consists of a rotating slotted disk and a fixed partial disk, also slotted.

Light sources and sensors are mounted so that the encoder generates two quasi-sinusoidal signals with a phase difference of $\pm 90^\circ$. These signals are referred to as FTA and FTB. The frequency of these signals indicates the speed of rotation and the rela-

tive phase difference indicates the direction of rotation. An example of this type is the Sensor Technology STRE 1601, which has 200 tracks. Similar types are available from a number of manufacturers including Sharp and Eleprint.

This encoder generates a third signal, FTF, which consists of one pulse per rotation. FTF is used to find the absolute position at initialization.

Figure 3 : The System operates with an Optical Encoder of the Type shown schematically here. It generates two Signals 90° out of Phase plus a one Pulse-per-rotation Signal.

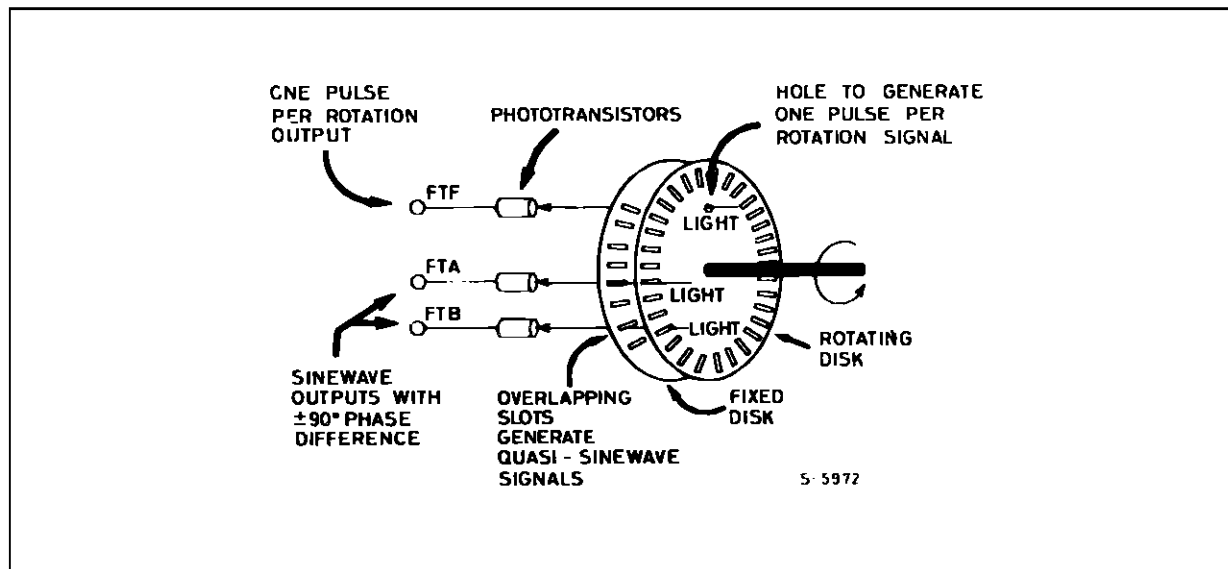

THE L290 TACHOMETER CONVERTER

The L290 tachometer converter processes the three optical encoder signals FTA, FTB, FTF to generate a tachometer voltage, a position signal and feedback signals for the microprocessor. It also generates a reference voltage for the system's D/A converter.

Analytically, the tacho generation function can be expressed as :

$$\text{TACHO} = \frac{dV_{AB}}{dt} \cdot \frac{FTA}{|FTA|} - \frac{dV_{AA}}{dt} \cdot \frac{FTB}{|FTB|}$$

In the L290 (block diagram, figure 4) this function is implemented by amplifying FTA and FTB in A1 and A2 to produce V_{AA} and V_{AB} . V_{AA} and V_{AB} are differentiated by external RC networks to give the signals V_{MA} and V_{MB} which are phase shifted and proportional in amplitude to the speed of rotation. V_{MA} and V_{MB} are passed to multipliers, the second inputs of which are the sign of the other signal before differentiation.

The sign $\left(\frac{FTA}{|FTA|} \text{ or } \frac{FTB}{|FTB|} \right)$ is provided by the

comparators CS1 and CS2. Finally, the multiplier outputs are summed by A3 to give the tacho signal. Figure 5 shows the waveforms for this process.

This seemingly complex approach has three important advantages. First, since the peaks and nulls of CSA and CSB tend to cancel out, the ripple is very small. Secondly, the ripple frequency is the fourth harmonic of the fundamental so it can be filtered easily without limiting the bandwidth of the speed loop. Finally, it is possible to acquire tacho information much more rapidly, giving a good response time and transient response.

Feedback signals for the microprocessor, STA, STB and STF, are generated by squaring FTA, FTB and FTF. STA and STB are used by the micro to keep track of position and STF is used at initialization to find the absolute position.

APPLICATION NOTE

Position feedback for the L291 is obtained simply from the output of A1.

The L290 also generates a reference voltage for the L291's D/A converter. This reference is derived from V_{AA} and V_{AB} with the function :

$$V_{ref} \equiv |V_{AA}| + |V_{AB}|$$

Figure 4 : The L290 processes the Encoder Signals, generating a Tacho Voltage and Position Signal for the L291 plus Feedback Signals for the Microprocessor. Additionally, it generates a Reference Voltage for the L291's D/A Converter.

Since the tacho voltage is also derived from V_{AA} and V_{AB} it follows that the system is self compensating and can tolerate variations in input levels, temperature changes and component ageing with no deterioration of performance.

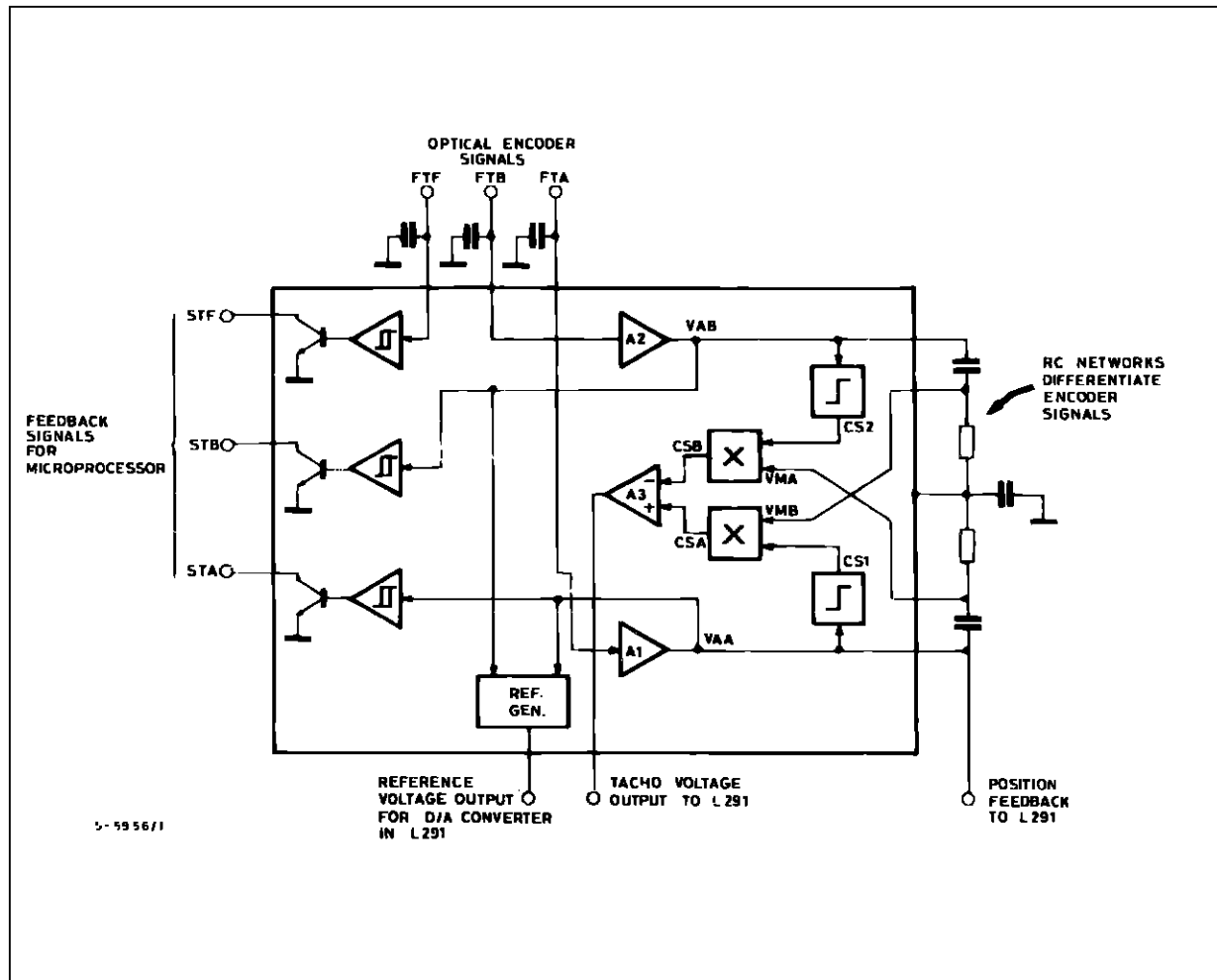

Figure 5 : These Waveforms illustrate the Generation of the Tacho Voltage in the L290. Note that the Ripple is fourth Harmonic. The Amplitude of TACHO is proportional to the Speed of Rotation.

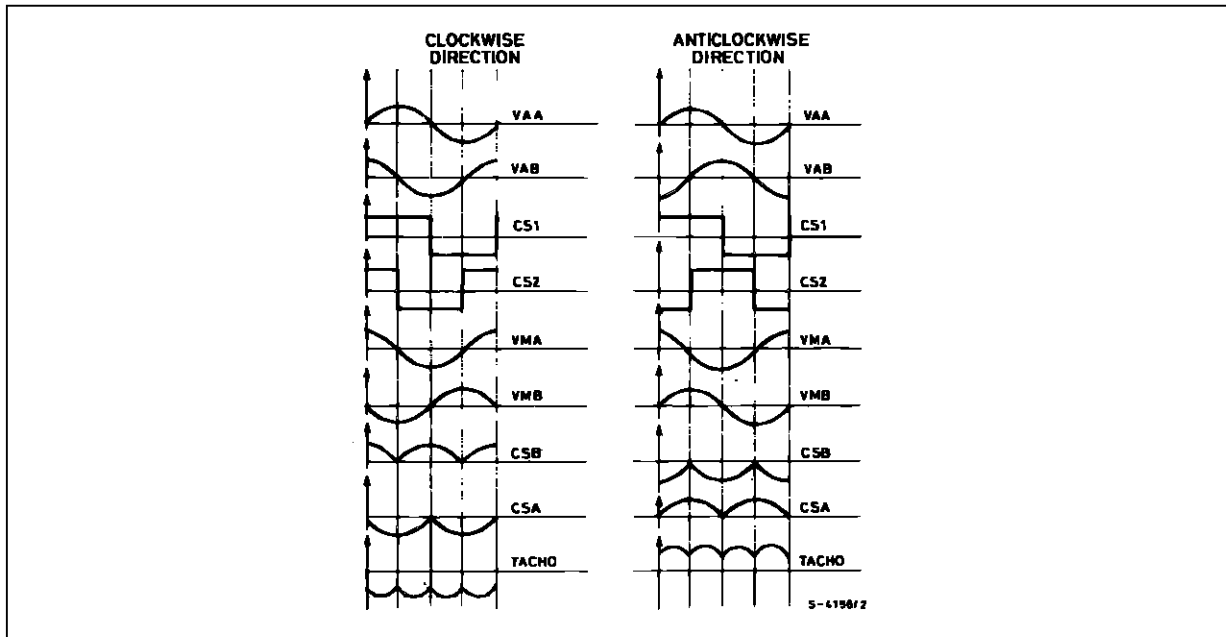
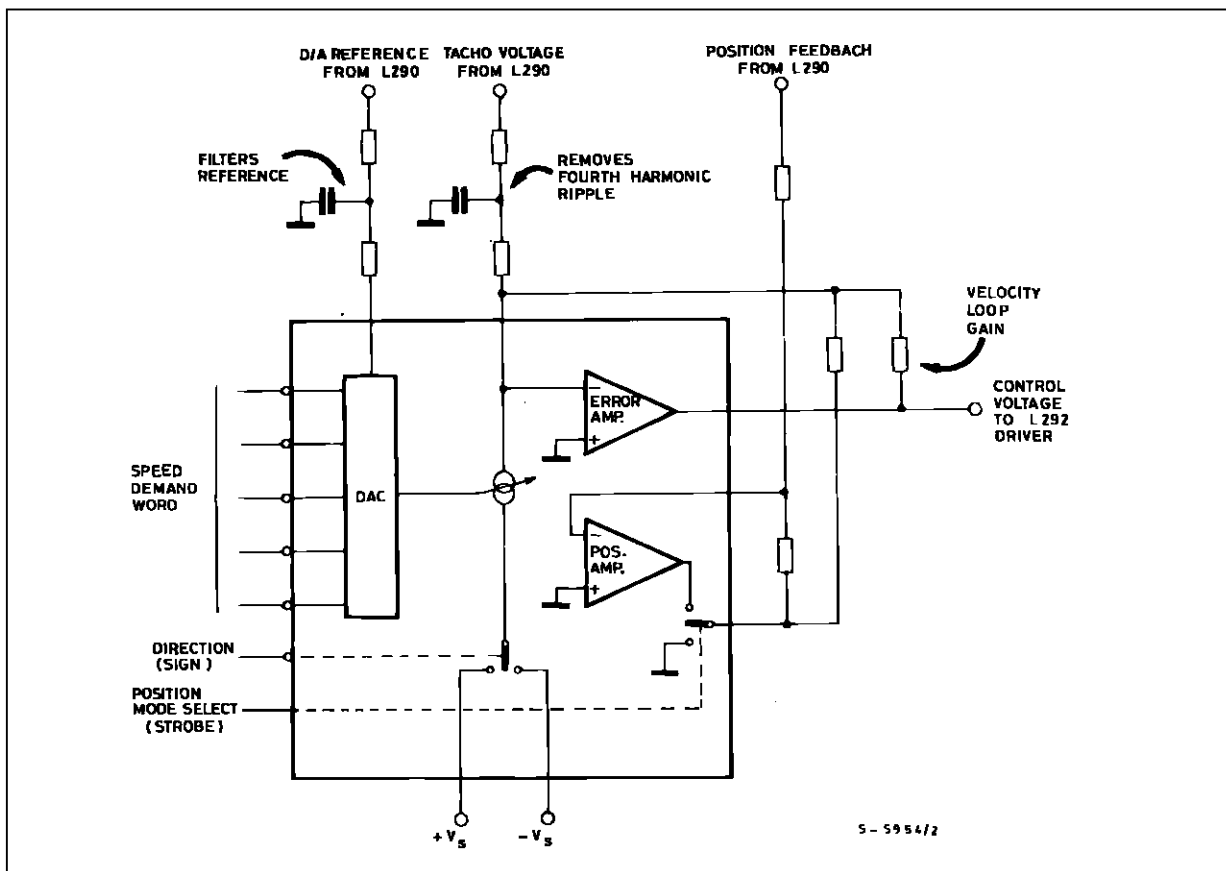

Figure 6 : The L291 Links the System to the Microprocessor. It contains the system DA converter, main error amplifier and position amplifier.



APPLICATION NOTE

THE L291 D/A CONVERTER AND AMPLIFIERS

The L291, shown in figure 6, links the system to the micro and contains the system's main error amplifier plus a position amplifier which allows independent adjustment of the characteristics of the position loop.

It contains a five bit D/A converter with switchable polarity that takes its reference from the L290. The polarity, which controls the motor direction, is controlled by the micro using the SIGN input.

The main error amplifier sums the D/A converter output and the tachometer signal to produce the motor drive signal ERRV. The position amplifier is provided to allow independent adjustment of the position loop gain characteristics and is switched in/out of circuit to select the mode. The final position mode is actually 'speed plus position' but since the tachometer voltage is almost zero when position mode is selected the effect of the speed loop is negligible.

THE L292 SWITCHMODE MOTOR DRIVER

The L292 can be considered as a power transconductance amplifier - it delivers a motor current proportional to the control voltage (ERRV) from the L291. It drives the motor efficiently in switchmode and incorporates an internal current feedback loop to ensure that the motor current is always proportional to the input control signal.

The input control signal (see block diagram, figure 7) is first shifted to produce a unipolar signal (the L292 has a single supply) and passed to the error amplifier where it is summed with the current feedback signal. The resulting error signal is used to modulate the switching pulses that drive the output stage.

External sense resistors monitor the load current, feeding back motor current information to the error amplifier via the current sensing amplifier.

The L292 incorporates its own voltage reference and all the functions required for closed loop current control of the motor. Further, it features two enable inputs, one of which is useful to implement a power on inhibit function.

The L292's output stage is a bridge configuration capable of handling up to 2A at 36V. A full bridge stage was chosen because it allows a supply voltage to the motor effectively twice the voltage allowed if a half bridge is used. A single supply was chosen to avoid problems associated with pump-back energy.

In a double supply configuration, such as the example in figure 8 a, current flows for most of the time through D1 and Q1. A certain amount of power is thus taken from one supply and pumped back into the other. Capacitor C1 is charged and its voltage can rise excessively, risking damage to the associated electronics.

By contrast, in a single supply configuration like figure 8b the single supply capacitor participates in both the conduction and recirculation phases. The average current is such that power is always taken from the supply and the problem of an uncontrolled increase in capacitor voltage does not arise.

A problem associated with the system used in the L292 is the danger of simultaneous conduction in both legs of the output bridge which could destroy the device. To overcome this problem the comparator which drives the final stage consists of two separate comparators (figure 9). Both receive the same V_t , the triangular wave from the oscillator, signal but on opposite inputs.

Figure 7 : The L292 Switchmode Driver receives a Control Voltage from the L291 and delivers a switchmode regulated Current to the Motor.

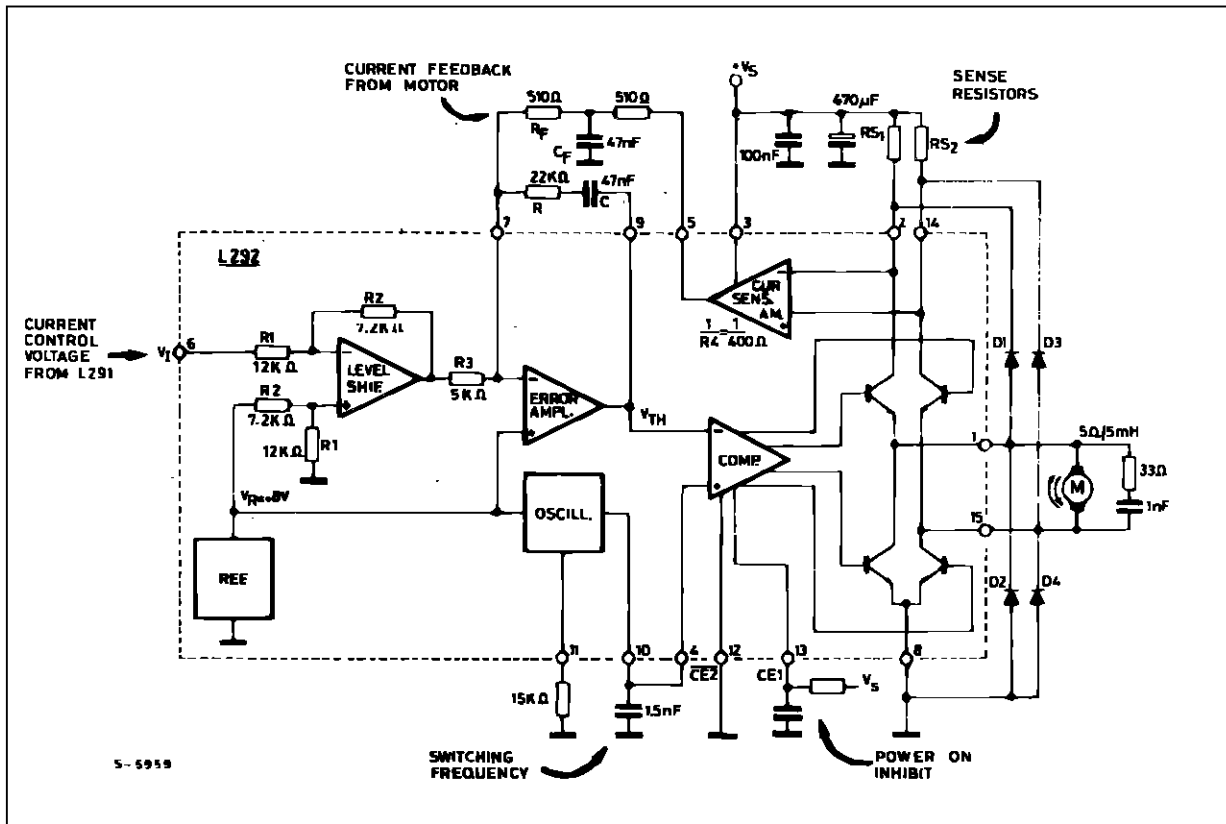
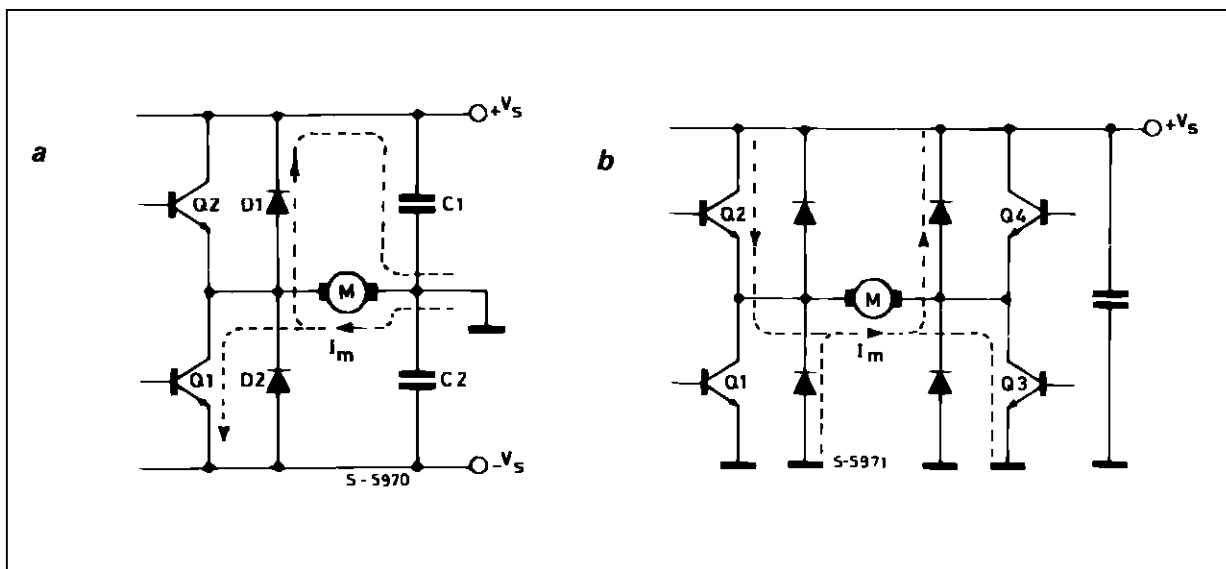

Figure 8 : A Simple Push Pull Output (a) needs a Split Supply and the Device can be damaged by the Voltage Built up on C1. The L292 has a Bridge Output to avoid these Problems. Only one Supply is needed and the Voltage across the Single Capacitor never rises excessively. Moreover, the Motor can be supplied with a Voltage up to twice the Voltage allowed with a Half Bridge.



APPLICATION NOTE

The other two inputs are driven by V_{TH} , the error amplifier output, shifted by plus or minus $R_T I'$. This voltage shift, when compared with V_t , results in a delay in switching from one comparator to the other.

Figure 9 : The L292's final Comparator actually consists of two Comparators. This Configuration introduces a Delay to prevent simultaneous Conduction of two Legs.

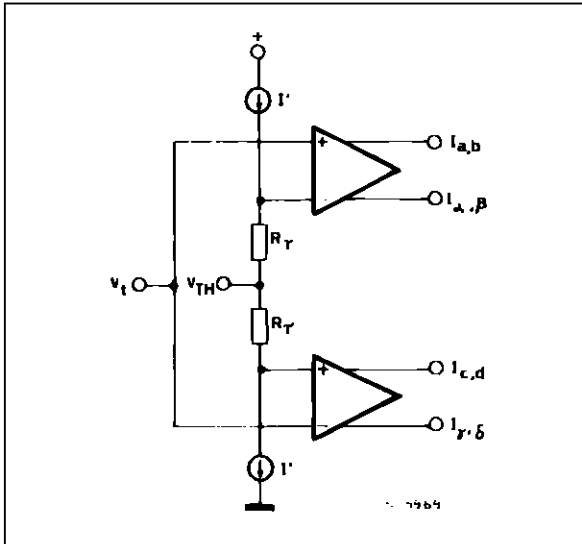

Consequently there will always be a delay between switching off one leg of the bridge and switching on the other. The delay τ is a function of the integrated resistor R_T (1.5k Ω) and an external capacitor C17 connected to pin 10 which also fixes the oscillator frequency. The delay is given by :

$$\tau = R_T C17$$

In multiple L292 configurations (in a typewriter, for example, there may be two systems) it is desirable to synchronise the switching frequencies to avoid intermodulation. This can be done using the configuration shown in figure 10.

Figure 10 : Ground Plane switching Noise and Modulation Phenomena are avoided in Multi-L292 Systems by synchronizing the Chopper Rate with this RC Network.

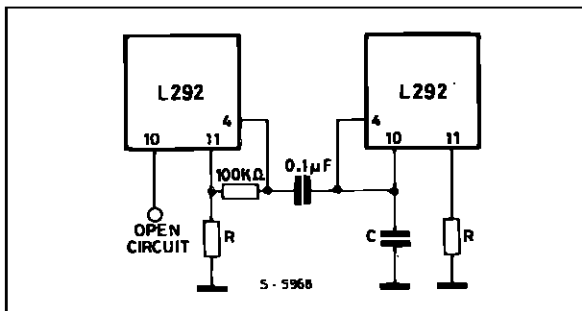

SOFTWARE AND INTERFACING TO THE MICRO

In a typical system the L290/1/2 system is connected to the control microcomputer through ten I/O lines : seven outputs and three inputs.

The outputs are all connected to the L291 D/A converter and consist of the five bit speed demand word, SIGN (which sets the direction) and the speed/position mode select line. Position feedback for the micro comes from the L290 tachometer and consists of the signals STA, STB (the squared encoder outputs) plus the one-pulse-per-rotation signal, STF (figure 11).

Figure 11 : In a typical system the L290/L291/L292 combination is linked to the micro through seven output lines, two inputs and an interrupt input.

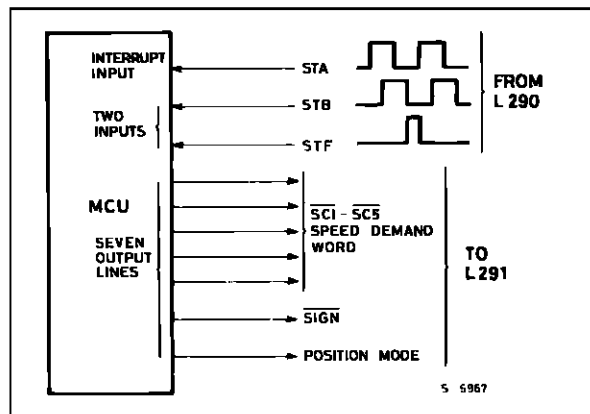

To follow the motor position the micro counts the STA pulses to measure the distance travelled and compares the phase of STA and STB to sense the direction. The most convenient way to do this is to connect the STA line to an interrupt input. An interrupt service routine will then sample STB and increment or decrement the position count depending on the relative phase difference : + 90° if STB is high ; -90° if STB is low.

It could be argued that the micro doesn't need to sense the direction of the rotation because it controls the direction. In practice, however, it is better to sense the direction to allow for the possibility that the motor may be moved by externally applied forces.

For each movement the micro calculates the distance to be travelled and determines the correct direction. It then sets the L291 to velocity feedback mode, sets the direction appropriately and sets the speed demand word for maximum speed (possibly less if the move is very short).

By means of the STA interrupt service routine it follows the changing position, reducing the speed de-

mand word to brake the motor when the target position is very close. Finally, the micro orders the L291 to switch to position loop control for the final precise positioning.

When the system is powered up the mechanical subsystem may be in any position so the first step is to initialize it. In applications where the optical encoder never rotates more than one revolution – the daisy wheel of a typewriter, for example – this is simply done by rotating the motor slowly until the STF signal (one-pulse-per-rotation) is detected.

Where the optical encoder rotates more than once the 'one-pulse-per-rotation' signal is not sufficient. An example of this is the carriage positioning servo of a computer printer. In this case the simplest solution is to fit a microswitch on one of the endstops. First the motor is run backwards slowly until the carriage hits the endstop. Then it moves forward until the STF signal is detected. The beauty of this solution is that the endstop microswitch does not need to be positioned accurately.

Figure 12 : Complete Application Circuit of the System.

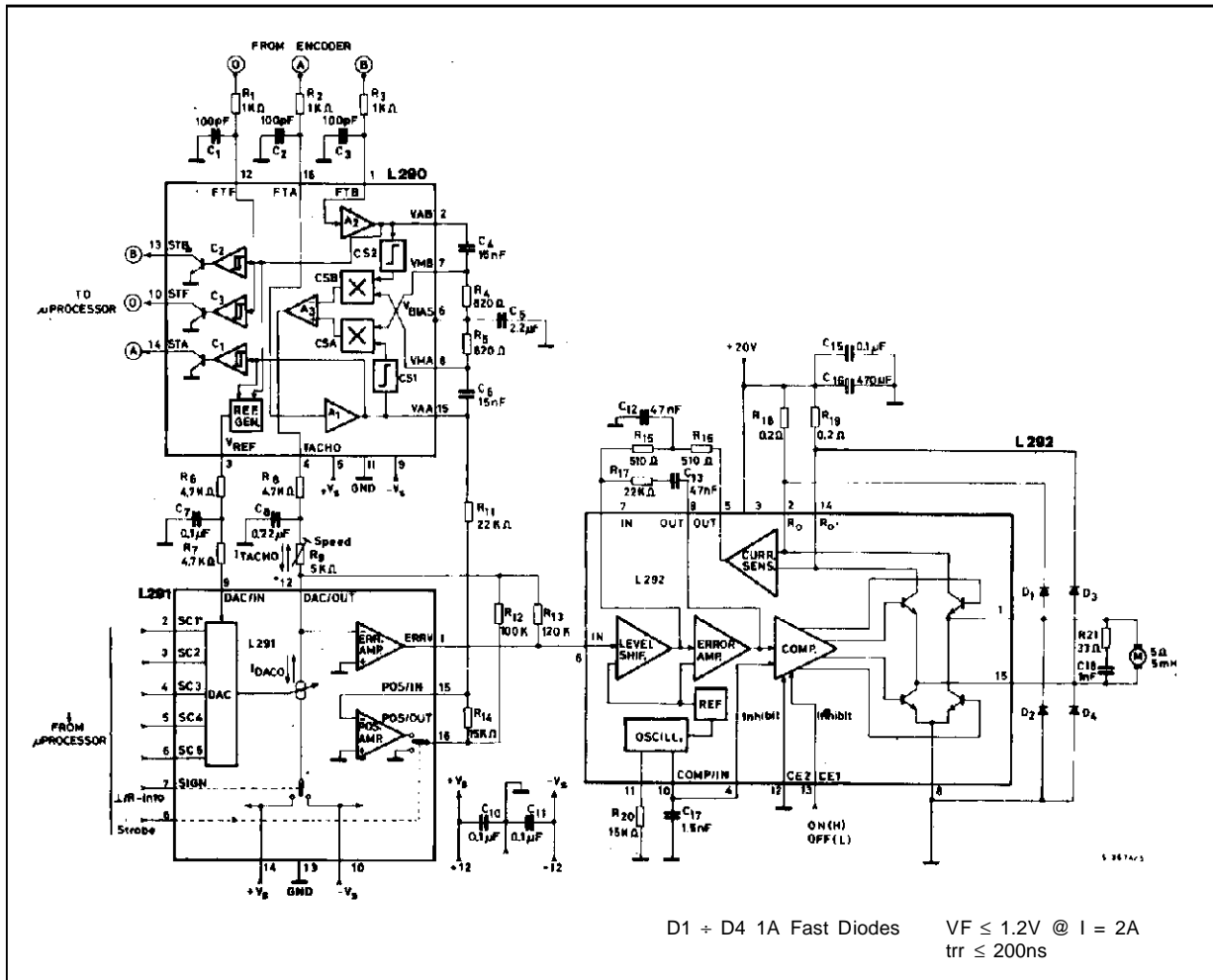

APPLICATION NOTE

Figure 13 : P.C. Board and Component layout (1 : 1 scale).

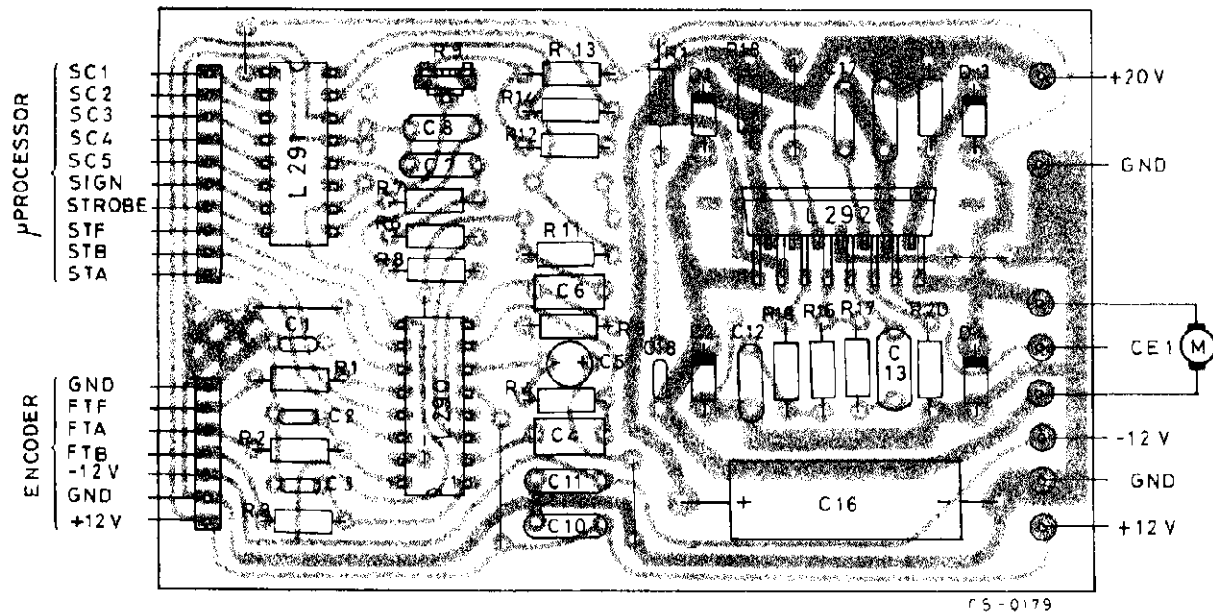

Figure 14.

Component	Recommended Value	Purpose	Larger than Recommended Value	Smaller than Recommended Value
R1, R2, R3	1 kΩ	To filter the noise on the encoder signals.	Offset voltage increase (V _{AA} , V _{AB}).	
R4, R5	820 Ω	Differentiator Network	Tacho offset and tacho signal increase.	Tacho offset increase. Tacho signal decrease.
R6, R7	4.7 kΩ	To set the D/A input current.	D/A input current decrease.	D/A input current increase.
R8	4.7 kΩ	To set the motor speed.	Motor speed increase.	Motor speed decrease.
R9	5 kΩ	To adjust the motor speed.	Danger of Oscillation $R9 \leq R13/10$	
R11	22 kΩ	To set the position loop gain.	- Position loop gain decrease.	- Position loop gain increase. - Danger of oscillation of the motor shaft.
R12	100 kΩ	To set the position loop gain.	- Position loop gain decrease.	- Position loop gain increase. - Danger of oscillation of the motor shaft.
R13	120 kΩ	To set the speed loop gain.	- Speed loop gain increase.	- Speed loop gain decrease.
R14	15 kΩ	To set the position loop gain.	- Position loop gain increase. - Danger of oscillation of the motor	- Position loop gain decrease.
R15, R16	510 Ω	To filter the feedback current.	Danger of output saturation of the current sensing amplifier $R15 + R16 \leq 3.3 \text{ k}\Omega$.	

Figure 14: (continued)

Component	Recommended Value	Purpose	Larger than Recommended Value	Smaller than Recommended Value
R17	22 k Ω	To set the gain of the err. amplifier.	Increase of the gain at high frequencies.	Danger of Oscillations R17 > 5.6 k Ω
R18, R19	0.2 Ω	To set the transconductance value of the L292.	Transconductance decrease (R18 , R15). $I_m \leq 0.44$ V.	Transconductance increase.
R20	15 k Ω	To set the oscillator frequency.	Oscillator frequency decrease.	Oscillator frequency increase. R20 \geq 8.2 k Ω
R 21	33 Ω	Compensation Network		Increase of the peak current in the output transistors during the communications.
C1, C2, C3	100 pF	To filter the noise on the encoder signals.	Bandwidth reduction of the low pass filter.	Bandwidth increment of the low pass filter.
C4, C6	15 nF	Differentiator Network	Tacho signal increase.	Tacho signal Decrease.
C5	2.2 μ F	By-pass Capacitor	Larger set-up time after power on.	Reduced by-pass effect at low frequencies.
C7	0.1 μ F	Low-pass filter for the D/A input current.		Increase of the current ripple at low speed.
C8	0.22 μ	– Low pass filter for the tacho signal. – To determine the dominant pole of the speed loop.	Bandwidth reduction of the speed loop.	Low filtering at low speed, causing noise on the motor.
C10, C11	0.1 μ F	Supply By-pass Capacitor		Danger of Oscillations.
C12	47 nF	To filter the feedback current	– Lower value of the damping factor. – Danger of Oscillations	– Higher value of dumping factor.
C13	47 nF	To set the gain of the error amplifier $C13 - R17 = L_M/R_M$		
C15	0.1 μ F	Supply By-pass Capacitor		Danger of Oscillations
C16	470 μ F	Supply By-pass Capacitor		Ripple increment on the supply voltage.
C17	1.5 nF	To set the oscillator frequency and the dead time of the output transistors.	– Oscillation Frequency Reduction – Dead time increment.	– Oscillation Frequency Increment – Dead time reduction.
C18	1 nF	Compensation Network		Danger of Oscillations
D1, D2, D3, D4	1 A Fast Diodes	Recirculation Diodes		

APPLICATION NOTE

APPLICATION CIRCUITS

The complete circuit is shown in figure 12 ; a suitable layout for evaluation is given in figure 13. Component values indicated are for a typical system using a Sensor Technology STRE1601 encoder and a motor with a winding resistance of 5Ω and an inductance of 5mH (this motor is described fully in figure 17). How to calculate values for other motors is explained further on.

Figure 14 explains what each component does and what happens if is varied. Maximum and minimum values are also indicated where appropriate.

ADDING DISCRETE TRANSISTORS FOR HIGHER POWER

In the basic application, the L292 driver delivers 2 A to the motor at 36V. This is fairly impressive for an integrated circuit but not enough for some applications - robots, machine tools etc. The basic system can be expanded to accommodate these applications by adding external power transistors to the L292.

This is preferable to simply adding a discrete driver stage in place of the L292 because the L292's current control loop is very useful.

Figure 15 shows how four transistors are added to increase the current to 4, 6 or 8A, depending on the choice of transistor. When coupled to the L290 and L291 this configuration appears to the system as an L292.

The average motor current, I_m , is found from :

$$I_m = \frac{V_i \cdot 0.044}{R_x}$$

Where V_i is the input voltage and R_x is the value of the sense and resistors R7 and R8.

Suitable transistors for this configuration are indicated below :

I(A)	V _i (V)	R _x (mΩ)	Q1, Q2	Q3, Q4	D1 - D4
4	9.1	100	BD708	BD707	2A Fast Diodes
6	9.1	65	BD908	BD907	3A Fast Diodes
8	9.1	50	BDW52A	BDW51A	4A Fast Diodes

Figure 15 : For higher power external transistors are added to the L292. This circuit delivers up to 4A, if 2 BDW51A and 2 BDW52A are used it can deliver 8A.

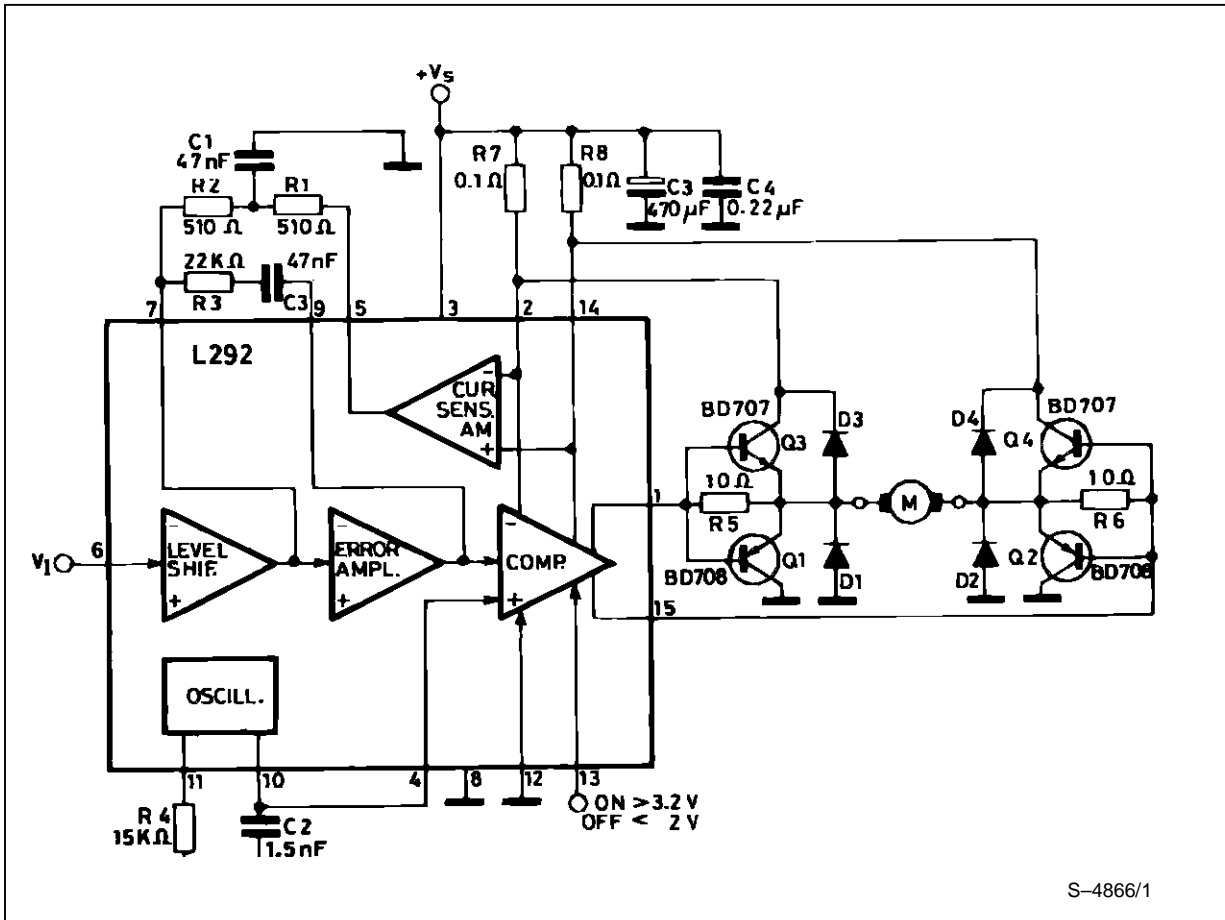

S-4866/1

The circuit shown in figure 16 is suitable for motor currents up to 50A at voltages to 150V. Two supplies are used ; 24V for the L292 and LS141 and 150V for the external transistors and motor. This circuit too behaves just like an L292, except for the higher power, and connects to the L290 and L291 as usual.

The motor current is given by :

$$I_m = \frac{V_{in} \times 120 \times 10^{-6} R}{R_s}$$

where $R_s = R_{s1} = R_{s2} = 12 \times 10^{-3} \Omega$

and $390 \Omega < R < 860 \Omega$

This gives a range of transconductance values (I_m/V_{in}) from 3.0A/V ($R = 390 \Omega$) to 8.6A/V ($R = 860 \Omega$).

In this circuit the L292 drives two transformers whose secondaries drive the power transistors. The coil ratio of the transformers is 1 : 20. To limit the duty cycle at which the transformers operate from 15% to 85%, two zener diodes are inserted between pin 7 and pin 9 of the L292. The LS141 op amp supplies current feedback from the transistor bridge to the L292.

Figure 16 : For higher voltages and currents—up to 150V at 50A, this circuit can be used. It connects to the L290 and L291, behaving just like and L292.

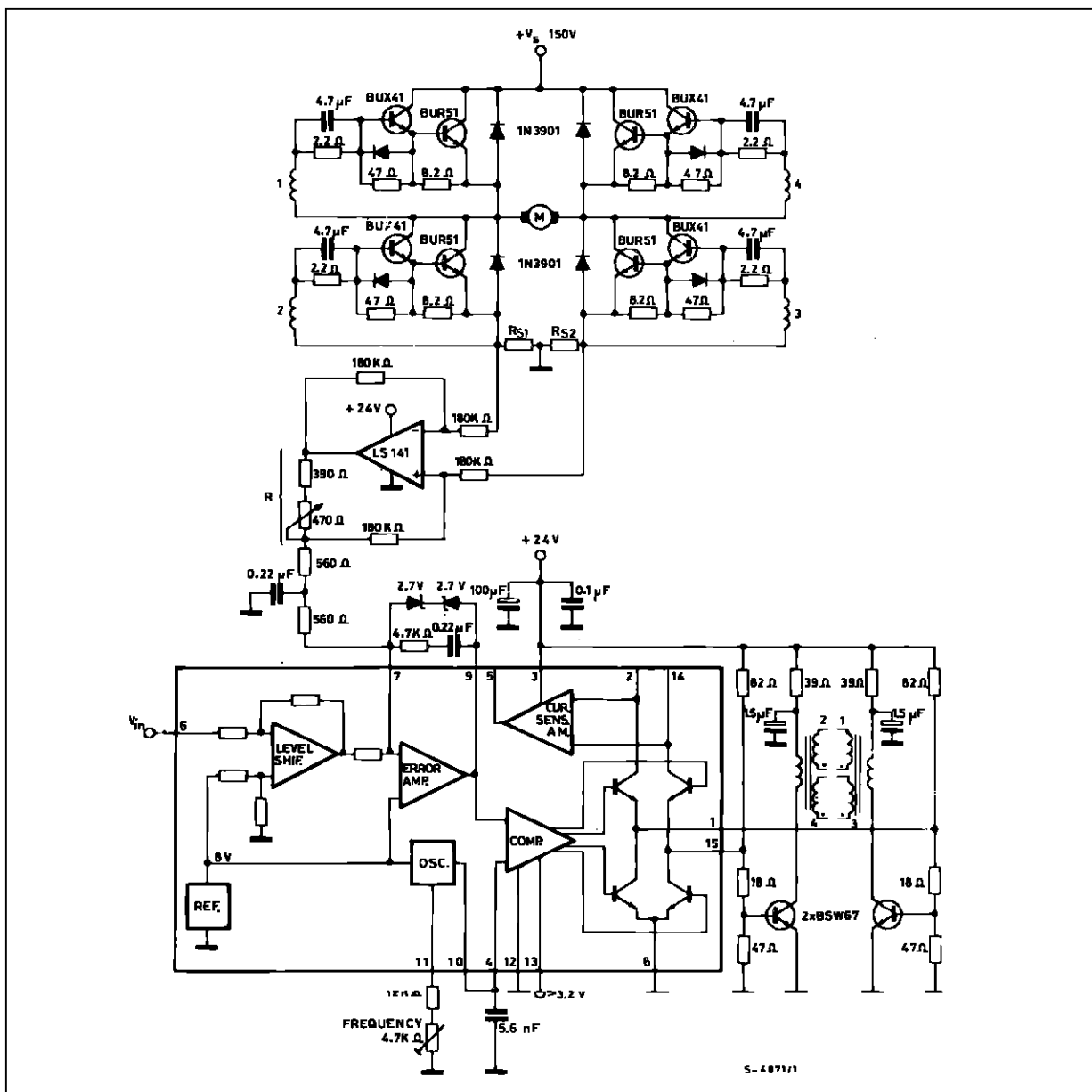

APPLICATION NOTE

DESIGN CONSIDERATIONS

The application circuit of figure 12 will have to be adapted in most cases to suit the desired performance, motor characteristics, mechanical system characteristics and encoder characteristics. Essentially this adaptation consists of choosing appropriate values for the ten or so components that determine the characteristics of the L290, L291 and L292.

The calculations include :

- Calculation of maximum speed and acceleration ; useful both for defining the control algorithm and setting the maximum speed.
- Calculation of R8 and R9 to set maximum speed.
- Laplace analysis of system to set C8, R11, R12, R13 and R14.
- Laplace analysis of L292 loop to set the sensing resistors and C12, C13, R15, R16, R17.
- Calculation of values for C4 and C6 to set max level of tach signal.
- Calculation of values for R6 and R7 to set D/A reference current.
- Calculation of R20 to set desired switching frequency.

MAXIMUM ACCELERATION

For a permanent magnet DC motor the acceleration torque is related to the motor current by the expression :

$$T_a + T_f = K_T I_m$$

where :

- I_m is the motor current
- K_T is the motor torque constant
- T_a is the acceleration torque
- T_f is the total system friction torque

The acceleration torque is related to angular acceleration and system inertia by :

$$T_a = (J_m + J_{oe} + J_L) a$$

where :

- J_m is the moment of inertia of the motor
- J_{oe} is the moment of inertia of the encoder
- J_L is the moment of inertia of the load
- a is the angular acceleration

In a system of this type the friction torque T_f is normally very small and can be neglected. Therefore, combining these two expressions we can find the angular acceleration from :

$$a = \frac{K_T}{J_m + J_{oe} + J_L} \cdot I_m$$

It follows that for a given motor type and control loop the acceleration can only be increased by increasing the motor current, I_m .

The characteristics of a typical motor are given in figure 17. From this table we can see that :

$$K_T = 4.3 \text{ N cm/A} \quad (6.07 \text{ oz. in/A})$$

$$J_m = 65 \text{ g} \cdot \text{cm}^2 \quad (0.92 \times 10^{-3} \text{ oz. in}^2)$$

We also know that the maximum current supplied by the L292 is 2 A and that the moment of inertia of the STRE 1601 optical encoder, J_{oe} , is $0.3 \times 10^{-4} \text{ oz. in} \cdot \text{s}^2$.

The moment of inertia of the load J_L , is unknown but assume, for example, that $J_{oe} + J_L \cong 2 J_m$. Therefore the maximum angular acceleration is :

$$a = \frac{6.07 \times 2}{2 \times 0.92 \times 10^{-3}} = 6597.8 \text{ rad/s}^2$$

Figure 17: The characteristics of a typical DC motor

Motor - Parameter	Value
U_{BB} (V_s)	18 V
C. emf. K_E	4.5 mV/min ⁻¹
N_o (without load)	3800 rpm
I_{om} (without load)	190 mA
T_f (friction torque)	0.7 N cm
K_T (motor constant)	4.3 N cm/A
Amature Moment of Inertia	65 g. cm. ²
R_M of the Motor	5.4 Ω
L_M of the Motor	5.5 mH

MAXIMUM SPEED

The maximum speed can be found from :

$$V_{S \min} = 2 V_{CEsat} + R_s I_m + K_e \Omega + R_m I_m$$

where :

$E = K_e \Omega$ is the internally generated voltage (EMF)

K_e is the motor voltage constant

Ω is the rotation speed of the motor.

For example, if $V_{S \min} = 20V$

$$2 V_{CEsat} + R_s I_m = 5V \text{ (from L292 datasheet)}$$

$$R_m I_m = 10.8V \text{ (} R_m = 5.4 \Omega \text{)}$$

we obtain :

$$K_e \Omega (E) = 4.2V$$

and

$$\Omega = \frac{4.2 V}{4.5 \text{ mV/min}^{-1}} = 933.3 \text{ rpm} = 97.74 \text{ rad/s}$$

The STRE1601 encoder has 200 tracks so this speed corresponds to :

$$V = \Omega \frac{200}{60} = 3111.1 \text{ tracks/s.}$$

The time taken to reach maximum speed from a standing start can be found from

$$\Delta t = \frac{\Omega}{a} = \frac{97.74 \text{ rad/s}}{6597.8 \text{ rad/s}^2} = 14.8 \text{ ms}$$

We can also express the acceleration in terms of tracks/s² :

$$K = \frac{V}{\Delta t} = \frac{3111.1 \text{ tracks/s}^2}{14.8 \text{ ms}} = 210209.5 \text{ tracks/s}^2$$

Therefore the number of tracks necessary to reach the maximum system speed for our example is :

$$p = \frac{V^2}{2K} = 23 \text{ tracks}$$

This information is particularly useful for the programmer who writes the control software.

SETTING THE MAXIMUM SPEED

The chosen maximum speed is obtained by setting the values of R6, R7, R8, R9, C4 and C6 (all shown on the application circuit, figure 12). This is how it's done :

The first step is to calculate R6 and R7, which define the DAC current reference. From the L291 datasheet we know that I_{ref}, the DA converter current reference, must be in the range 0.3mA to 1.2mA.

Choosing an I_{ref} of roughly 0.5mA, and knowing that V_{ref} (the L290's reference output) is typically 5V, it follows that :

$$R6 + R7 = \frac{V_{ref}}{I_{ref}} = 10 \text{ k}\Omega$$

Therefore we can choose R6 = R7 = 4.7kΩ (5% tolerance).

Substituting the minimum and maximum values of V_{ref} (from the L290 datasheet) and the resistance

variations we can now check that the variation of I_{ref} in the worst case is acceptable.

$$I_{ref \text{ min}} = \frac{V_{ref \text{ min}}}{(R6 + R7)_{\text{max}}} = 0.46 \text{ mA}$$

$$I_{ref \text{ typ}} = \frac{V_{ref \text{ (typ)}}}{4.7 \text{ k} + 4.7 \text{ k}} = 0.53 \text{ mA}$$

$$I_{ref \text{ max}} = \frac{V_{ref \text{ max}}}{(R6 + R7)_{\text{min}}} = 0.62 \text{ mA}$$

These values are within the 0.3mA to 1.2mA limits.

Now that the reference current is defined we can calculate values for R8 and R9 which define the tachometer current at the summing point.

The full scale output current of pin 12 of the L291 (the D/A converter output) is :

$$I_o = 1.937 I_{ref}$$

which is typically 1.02mA.

The worst case output current is when I_{ref} is at a maximum (0.62mA) and the I_{out} error is maximum (+ 2 %) :

$$I_o = 0.62 \times 1.937 \times 1.02 = 1.22 \text{ mA}$$

This is less than the 1.4 mA maximum value for I_{out} specified in the L291 datasheet.

Assuming that the maximum DC voltage at the TACHO output of the L290 (pin 4) is 7V (this is the tachometer voltage generated at the maximum system speed), we can find the sum of R8 and R9 ;

$$R8 + R9 = \frac{V_{\text{tachometer DC}}}{I_{o \text{ typ}}} = \frac{7}{1.02} = 6.85 \text{ k}\Omega$$

Therefore we choose R8 = 4.7kΩ and a 5kΩ trimmer for R9. R9 is used to adjust the maximum speed.

We can now calculate the ripple voltage and maximum tachometer voltage :

$$V_{\text{ripple pp}} = \frac{\pi}{4} (\sqrt{2} - 1) V_{\text{tachometer DC}} \cong 2.3 V_{pp}$$

$$V_{\text{tachometer max}} = \frac{\pi}{4} \sqrt{2} V_{\text{tachometer DC}} \cong 7.8 V_p$$

APPLICATION NOTE

This value is within the voltage swing of the tachometer amplifier ($\pm 9V$); that means the choice of $V_{\text{tacho DC}} = 7V$ is correct.

At this point we know the values of R6, R7, R8 and R9. The maximum speed can now be set by choosing values for C4 and C6 which form the differentiation networks on the L290. These values depend on the number of tracks of the optical encoder. For the STRE1601 encoder the capacitor values can be found from figure 18. These curves show how the capacitor values is related to frequency (encoder rotation speed) for different tachometer voltages and maximum speed. The example values are $V_{\text{tacho DC}} = 7V$ and maximum speed = 3111 tracks/sec therefore the value for C4 and C6 is 15nF.

The values of R4 and R5 must be 820Ω to minimize the offsets.

Figure 18 : C4 and C6 value versus rotation speed for various maximum tachometer voltage values.

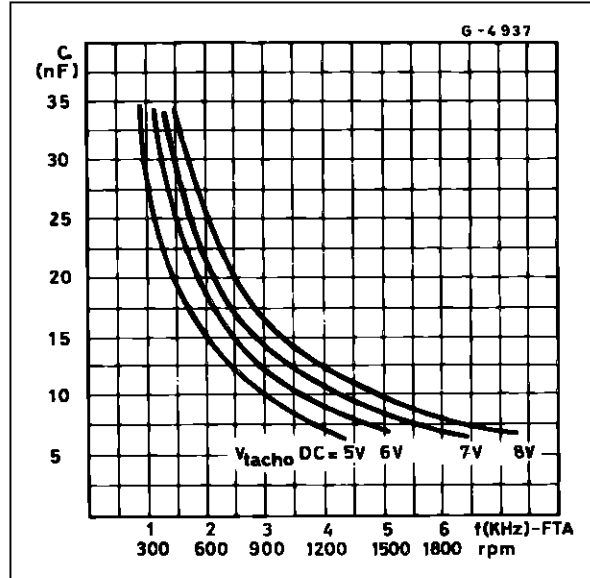
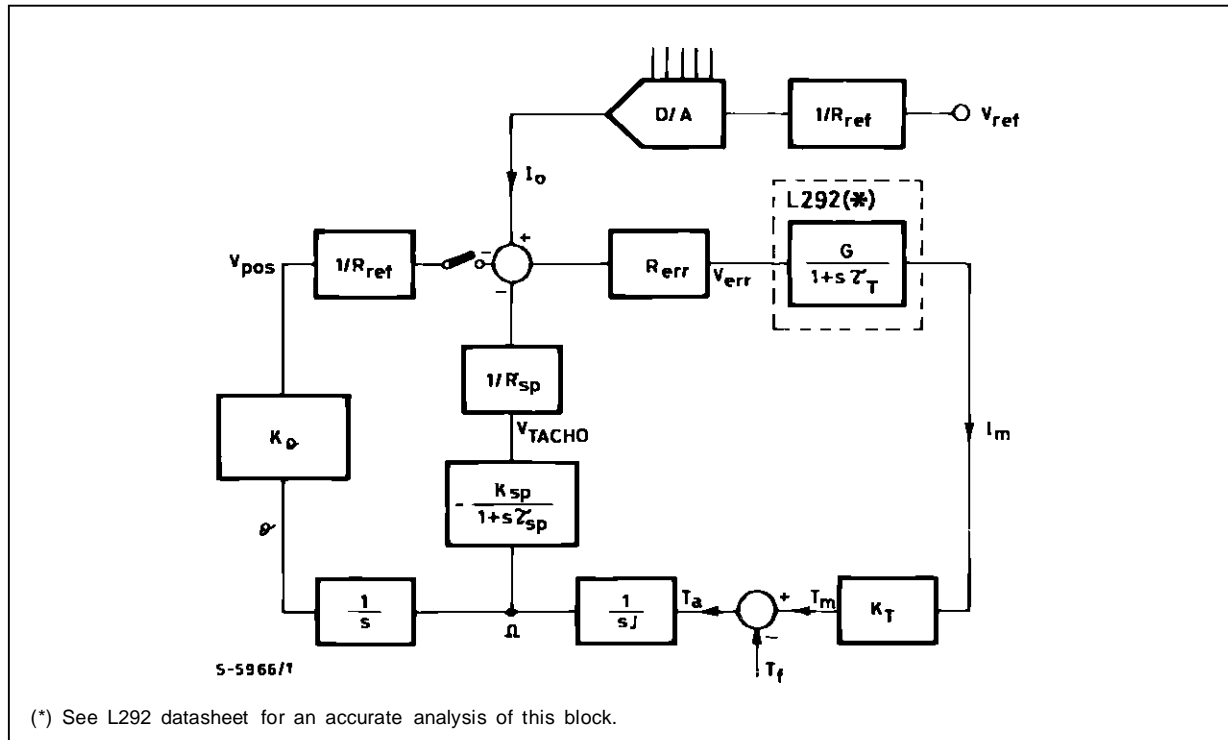

Figure 19.



List of terms

s : Laplace variable
 K_T : Motor torque constant
 T_a : Acceleration torque
 T_f : Total system friction torque
 J : Total moment of inertia ($J = J_{oe} + J_m + J_l$).

Ω : Speed
 θ : Angular position
 K_{sp} : Conversion factor that links the motor rotation speed and the TACHO signal.
 K_T : Conversion factor that links the motor position and the V_{pos} signal.

LAPLACE ANALYSIS OF THE SYSTEM

Table values for the components R11, R12, R13, R14 and C8 can be found from a Laplace analysis of the system. Figure 19 shows a simplified block diagram of the system which will be useful for the analysis.

The analysis is based on the angular speed Ω and on the motor position θ . The motor is represented, to a first approximation, by the current I_m and by the acceleration torque, T_a , which drives an inertial load J .

There are two conversion factors, K_{sp} and K_{θ} . They link the mechanical parameters (position and speed) with the equivalent feedback signals for the two loops. The values of K_{sp} and K_{θ} are determined by the encoder characteristics and the gain parameters of the integrated circuits. The openloop and closed-loop gains are fixed by four external resistors :

- R_{ref} – fixes the reference current (R6 + R7)
- R_{speed} – fixes the speed loop gain (R8 + R9)
- R_{pos} – controls the position loop gain (R12)
- R_{err} – controls the system loop gain (R13).

The stability both of the speed loop and of the speed-position loop are defined by external components.

The fundamental characteristics of the speed control system can thus be determined by the designer.

τ_{sp} is the time constant that determines the dominant pole of the speedloop and is determined by C8, R8 and R9

$$\tau_{sp} = C8 \frac{R8 R9}{R8 + R9}$$

SETTING THE L292 COMPONENTS

The sensing resistor and feedback loop component values for the L292 can be calculated easily using the following formulae. A detailed Laplace analysis of this block is given on the L292 datasheet.

a) Sense resistors. $R_s = R18 = R19$

$$\frac{I_m}{V_i} = \frac{R2 R4}{R1 R3} \cdot \frac{1}{R_s}$$

$$\Rightarrow R_s = \frac{R2 R4 V_i}{I_m R1 R3}$$

(These resistors are all inside the L292).

where :

I_m is the motor current

V_i is the input voltage corresponding to I_m .

For example, $I_m = 2 A$, $V_i = 9.1 V$, resistor values as in figure 7 (L292 internal block diagram)

$$R_s = \frac{0.044}{I_m} \quad V_i = 0.2 \Omega$$

b) R17, R15, R16, C12, C13

$$G_{mo} = \frac{2 V_s}{R_m V_R}$$

V_s = L292 supply voltage

R_m = motor resistance

V_R = L292 reference voltage

and

$$\xi = \sqrt{\frac{R4 C13}{4 R15 C12 G_{mo} R_s}}$$

$R4$ = L292 internal resistor (400 Ω)

$R_s = R18 = R19$

A good choice for ξ is $1/\sqrt{2}$. Substituting this value, G_{mo} and the values of $R4$ and R_s :

$$\xi^2 = \frac{1}{2} = \frac{400 C13}{4 R15 C12 \times 0.2}$$

$$\Rightarrow \frac{1000 C13}{R15 C12} = 1$$

Also $f_T = \frac{0.9}{2 \pi R15 C12}$

Assuming that f_T is 3kHz, another recommended value :

$$R15 C12 \cong 47 \times 10^{-6}s$$

Therefore we can find C13 :

$$1000 C13 \cong 47 \times 10^{-6}$$

$$\Rightarrow C13 = 47nF$$

Since

$$\frac{L_m}{R_m} = R17 C13$$

$$R17 = \frac{L_m}{C13 R_m}$$

For the example motor $L_m = 5mH$, $R_m = 5.4\Omega$ therefore :

$$R17 = \frac{L_m}{C13 R_m} = 22k\Omega$$

From $R15 C12 \cong 47 \times 10^{-6} s$, choosing a value of $R15$; 510 Ω , we have :

$$C12 = 82nF$$

Also, $R16 = R15 = 510\Omega$.

APPLICATION NOTE

DEAD TIME

C17 sets the switching delay of the L292 which protects against simultaneous conduction. The delay is :

$$\tau = R_{\tau} C17$$

and R_{τ} is an internal 1.5k resistor. The suggested 1.5nF value gives a switching delay of about 2.25 μ s. This is more than adequate because the transistors have a switch off delay of only 0.5 μ s.

SWITCHING FREQUENCY

The switching frequency is set by C17 and R20 :

$$f_{osc} = \frac{1}{2 R20 C17}$$

R20 must be at least 8.2k Ω and is varied to set the frequency : the value of C17 is imposed by dead time requirements. Typically the frequency will be 15-20kHz.

It should be outside the audio band to reduce noise but not too high or efficiency will be impaired. The maximum recommended value is 30kHz.

CURRENT RIPPLE

To reduce dissipation in the motor and the peak output current the ripple, ΔI_m , should be less than 10% of the maximum current.

Since

$$\Delta I_m = \frac{V_s}{L_m} \cdot \frac{T}{2}$$

($\frac{T}{2}$ = half period oscillator)

and

$$\Delta I_m = 0.1 I_{m \max}$$
$$0.1 I_{m \max} = \frac{V_s}{2 f L_{M \min}}$$
$$L_{M \min} = \frac{5 V_s}{f I_{m \max}}$$

Therefore there is a minimum inductance for the motor which may not always be satisfied. If this is the case, a series inductor should be added and the value is found from :

$$L_{\text{series}} = \frac{5 V_s}{f I_{m \max}} - L_M$$

EFFICIENCY AND POWER DISSIPATION

Neglecting the losses due to switching times and the dissipation due to the motor current, the efficiency of the L292's bridge can be found from :

$$\eta = 1 - \frac{\Delta t1}{\Delta t1 - \Delta t2} \cdot \frac{V_{sat}}{V_s} - \frac{\Delta t1}{\Delta t - \Delta t2} \cdot \frac{V_{over}}{V_s}$$

where :

$$V_{over} \cong 2V (2V_{BE} + R_s I_m)$$

$$V_{sat} \cong 4V (2V_{CEsat} + 3 V_{BE})$$

$\Delta t1$ = transistor conduction period

$\Delta t2$ = diode conduction period.

If $\Delta t1 \geq \Delta t2$ and $V_s = 20V$ we obtain :

$$\eta = 1 - \frac{4}{20} = 80\%$$

In practice the efficiency will be slightly lower as a result of dissipation in the signal processing circuit (about 1W at 20V) and the finite switching times (about 1W).

If the power transferred to the motor is 40W, the 80% efficiency implies 10W dissipated in the bridge and a total dissipation of 12W. This gives an actual efficiency of 77%. Since the L292's Multiwatt package can dissipate up to 20W it is possible to handle continuous powers in excess of 60W.

POSITION ACCURACY

The main feature of the system L290, L291, L292 is the accurate positioning of the motor. In this section we will analyse the influence of the offsets of the three ICs on the positioning precision.

When the system is working in position mode, the signal FTA coming from the optical encoder, after suitable amplification, is sent to the summing point of the error amplifier (L291). If there were no offset and no friction, the motor would stop in a position corresponding to the zero crossing of the signal FTA, and then at the exact position required. With a real system the motor stops in a position where FTA has such a value to compensate the offsets and the friction ; as a consequence there is a certain imprecision in the positioning. The block diagram, fig. 20, shows the parts of the 3 ICs involved in the offsets. First we will calculate the amount of the offsets at the input of the IC L292 (point A of fig. 20).

Figure 20.

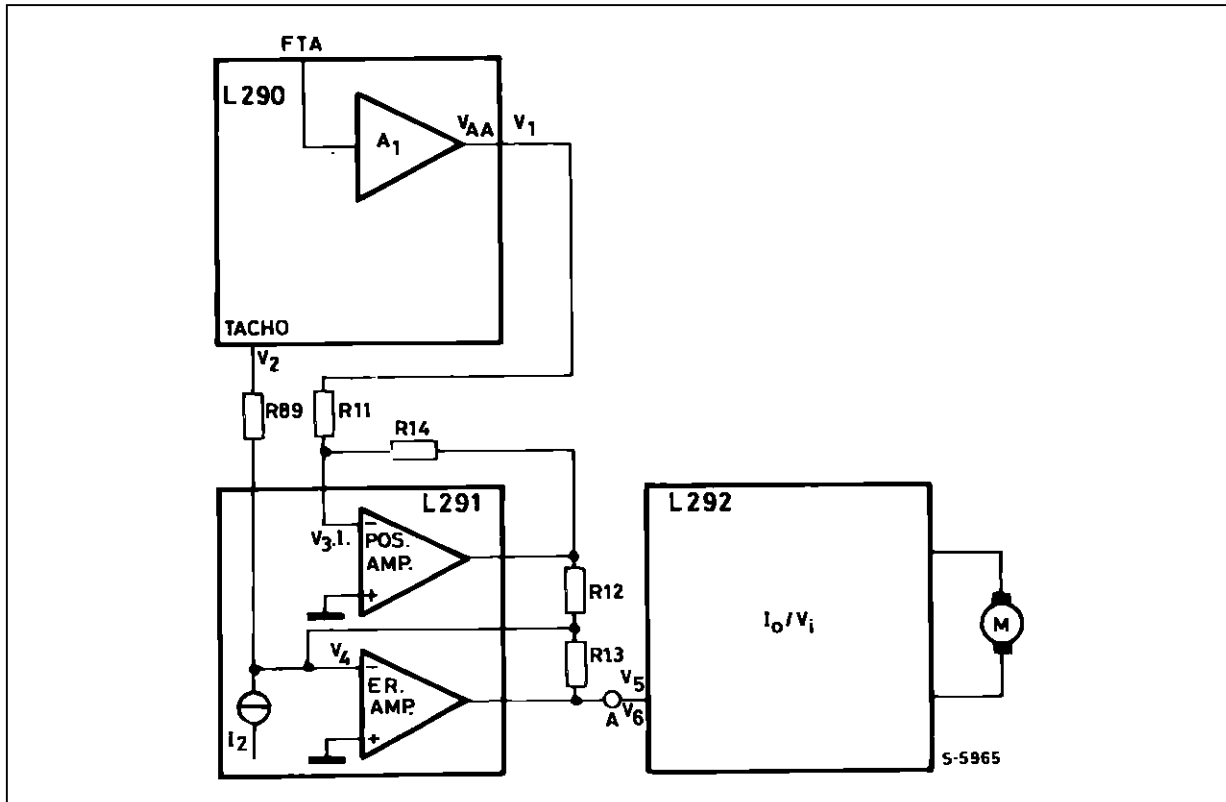

L290

The offset of the TACHO signal, V2, is the main cause of the imprecision of the positioning. Another offset in L290 is V1, the output offset voltage of A1. The contribution at point A is :

$$V_{1A} = V1 \cdot \frac{R14}{R11} \cdot \frac{R13}{R12}$$

$$V_{2A} = V2 \cdot \frac{R13}{R89}$$

L291

In this IC there are the following offsets :

- V3 = input offset voltage of the position amplifier
- I1 = input bias current of the position amplifier
- I2 = output offset current of the D/A converter plus ER. AMP bias current
- V4 = input offset voltage of the error amplifier.

Their contribution at point A is:

$$V_{3A} = V3 \cdot \left(1 + \frac{R14}{R11} \right) \cdot \frac{R13}{R12}$$

$$V_{1A} \pm I1 \cdot R14 \cdot \frac{R13}{R12}$$

$$V_{12A} = I2 \cdot R13$$

$$V_{4A} = V4 \left(1 + \frac{R13}{R12 // R89} \right)$$

L292

Referring to this IC we must consider the input offset voltage V5. Moreover, we call V6 the input voltage that must be applied to the L292 to keep the motor in rotation, i.e. to compensate the dynamic friction. V6 is not an offset voltage, but has the same effects, and for this reason we have to put it together with the offsets.

$$V_{5A} = V5 \quad \frac{I_o}{V_i} = \text{Transconductance of L292}$$

$$V_{6A} = V6 = \frac{I6}{\left[\frac{I_o}{V_i} \right]}$$

APPLICATION NOTE

I_6 = Motor current necessary to compensate the dynamic friction

The total offset voltage referred to point A is given by the sum of all the precedent terms :

$$V_A = V_{1A} + V_{2A} + V_{3A} + V_{I1A} + V_{I2A} + V_{4A} + V_{5A} + V_{6A}$$

The amplitude of the signal FTA necessary to compensate the offset V_A is :

$$V_{FTA} = V_A \cdot \frac{R_{12}}{R_{13}} \cdot \frac{R_{11}}{R_{14}} \cdot \frac{1}{A_1}$$

Calling V_M the maximum value of the signal FTA, the phase error of the system is :

$$\alpha = \sin^{-1} \frac{V_{FTA}}{V_M}$$

If α_c is the phase between two consecutive characters, (it may be equal 360° or multiple of it) the percentage error in the character positioning is :

$$\varepsilon = \frac{\alpha}{\alpha_c} \cdot 100$$

In these calculations we have not considered how the precision of the signal FTA, coming from the optical encoder, influences the positioning error. The percentage value of the pitch accuracy must be added to ε to have the total percentage error in the character positioning. Any DC offset of the mean value of the signal FTA must be multiplied by A_1 and added to V_1 to obtain its effect on the error.

NUMERICAL EXAMPLE

In this numerical example we will calculate the precision of the positioning in the worst case, i.e. with all the offsets at the max value. The values of the external components are taken from the application circuit. (fig. 12).

$$R_{11} = 22K \quad R_{12} = 100K \quad R_{13} = 120K \quad R_{14} = 15K \\ R_{89} = R_8 + R_9 = 6K$$

From the data sheets of the three ICs we can find :

$$V_1 = 55mV \quad V_2 = 80mV \quad V_3 = 4.5mV$$

$$V_4 = 2mV \quad V_5 = 350mV$$

$$I_1 = 0.3\mu A \quad I_2 = 0.4\mu A$$

$$A_1 \text{ min} = 22dB = 12.6$$

$$\frac{I_0}{V_i} \text{ min} = 205 \quad \frac{mA}{V}$$

$$V_{M\text{min}} = 0.4 V$$

For I_6 we will consider the value $I_6 = 50mA$

$$V_{1A} = 55 \cdot 10^{-3} \cdot \frac{15}{22} \cdot \frac{120}{100} = 45mV$$

$$V_{2A} = 80 \cdot 10^{-3} \cdot \frac{120}{6} = 1.6V$$

$$V_{3A} = 4.5 \cdot 10^{-3} \left(1 + \frac{15}{22}\right) \cdot \frac{120}{100} = 9.1mV$$

$$V_{I1A} = 0.3 \cdot 10^{-6} \cdot 15 \cdot 10^3 \cdot \frac{120}{100} = 5.4mV$$

$$V_{I2A} = 0.4 \cdot 10^{-6} \cdot 120 \cdot 10^3 = 48mV$$

$$V_{4A} = 2 \cdot 10^{-3} \cdot \left(1 + \frac{120}{5.6}\right) = 44.9mV$$

$$V_{5A} = 350mV$$

$$V_{6A} = \frac{50}{205} = 244mV$$

$$V_A = 2.346V$$

$$V_{FTA} = 2.329 \cdot \frac{100}{120} \cdot \frac{22}{15} \cdot \frac{1}{12.6} = 0.228V$$

$$\alpha = \sin^{-1} \frac{0.226}{0.4} \cong 35^\circ$$

If we consider an optical encoder with 200 tracks/turn and a daisy wheel with 100 characters, the phase between two consecutive characters is $\alpha_c = 720^\circ$, and then the maximum percentage error we can have is.

$$\varepsilon = \frac{35}{720} \cdot 100 \cong 4.8\%$$

From this numerical example we can see that the main contribution to the positioning error is given by the offset of the TACHO signal (V_{2A}), other big contributions are given by the input offset voltage of L292 (V_{5A}) and by the voltage necessary to compensate the dynamic friction of the motor (V_{6A}). This last term is only determined by the motor and can also have greater values.

The error we have calculated is the maximum possible and it happens when all the offsets have the max value with the same sign, i.e. with a probability given by the product of the single probabilities. Considering as an example every offset has a probability of 1% to assume the max value, the probability the error assumes the max value is :

$$P = (10^{-2})^7 = 10^{-14}$$

Figure 21.

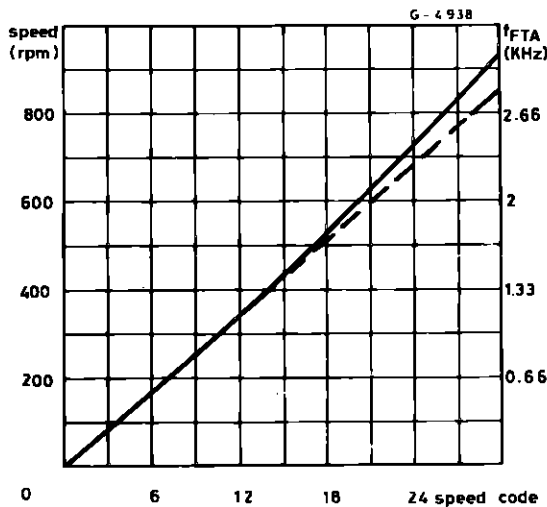

SPEED ACCURACY

If we consider the complete system with L290-L291-L292 driving a DC MOTOR with optical encoder, we can note the speed of the motor is not a linear function of the speed digital code applied to L291. The diagram of fig. 21 shows this function and it is evident that the speed increases more than a linear function, i.e. if the speed code doubles, the speed of the motor becomes more than the double. The cause of this non linearity is the differentiator network R4 C4 and R5 C6 (see fig. 22) that has not an ideal behaviour at every frequency.

Figure 22.

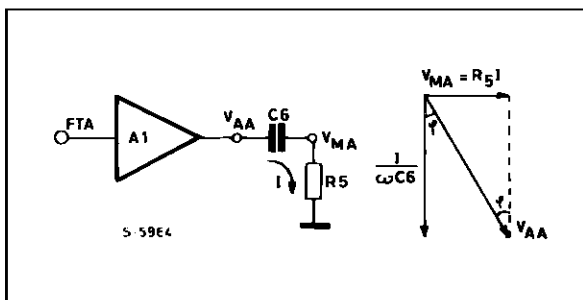

- 1) $V_{MA} = V_{AA} \sin \varphi$
- $\varphi = \text{tg}^{-1} \omega R5 C6$ $\omega = 2 \pi f$
- 2) $V_{MA} = V_{AA} \sin \text{tg}^{-1} \omega R5 C6$
- $f = \text{frequency of the signal FTA}$

This last relation gives the amplitude of the signal V_{MA} ; it is evident there is not a linear function between V_{MA} and ω , like $V_{MA} = K\omega$ and the difference is greater if the product $\omega R5 C6$ doesn't respect the disequation $\omega R5 C6 \ll 1$, i.e. at high frequencies.

Figure 23.

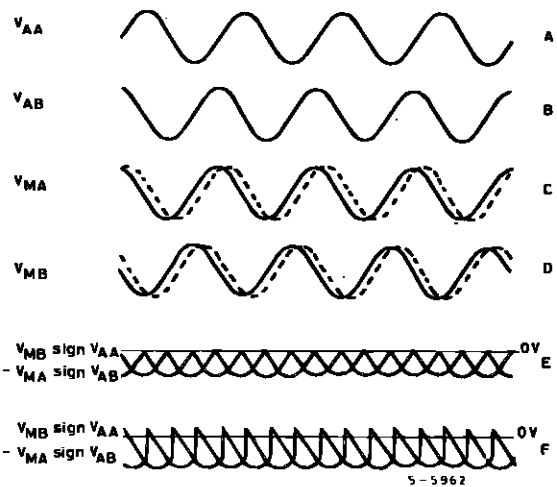

The phase angle between V_{MA} and V_{AA} should be 90° and then $\varphi = 0$, in our case φ increases with the frequency according to the equation $\varphi = \text{tg}^{-1} \omega R5 C6$, and influences the amplitude of the output signal TACHO. In fig. 23 are shown the waveforms that contribute to generate the TACHO signal. A and B are the signals V_{AA} and V_{AB} in phase with the input signals FTA and FTB. C and D are the signals V_{MA} and V_{MB} : the continue line indicate the ideal case, in fact the phase between V_{MA} and V_{AA} is 90° ; the dotted line is referred to the real case in which the phase is lower than 90° . By adding the two signals shown in E we obtain the TACHO signal, whose expression is :

Figure 24.

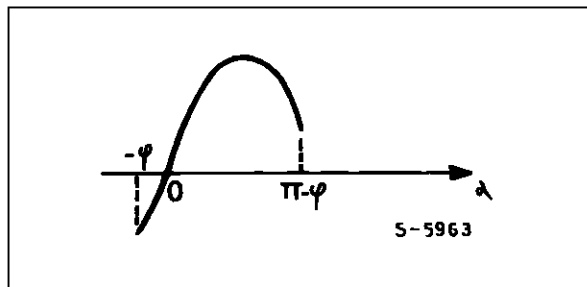

$V_{TACHO} = V_{MB} \cdot \text{sign } V_{AA} - V_{MA} \cdot \text{sign } V_{AB}$.

The signals in E are referred to the ideal case, the ones in F to the real case. It is possible to demonstrate the mean value of the TACHO signal in the real case is lower than the one we could have with an ideal differentiator network and this explains why in fig. 21 the speed of the motor increases more than a linear function. The mean value of the waveforms F is (fig. 24).

APPLICATION NOTE

$$3) V_m = \int_{-\varphi}^{\pi - \varphi} K1 \sin \alpha d\alpha = \frac{2K1}{\pi} \cos \varphi$$

Since the waveforms E are half sinewaves, the mean value is

$$4) V'_m = \frac{2 K1}{\pi}$$

We can conclude that two causes contribute to give a TACHO signal lower than the theoretical one, both due to differentiator network :

a) the amplitude of the signal V_{MA} is lower than $V_{MA} = K\omega$ and we can call ϵ_1 the relative percentage error.

$$\epsilon_1 = \frac{\sin \text{tg}^{-1} \omega R5 C6 - \omega R5 C6}{\omega R5 C6} \cdot 100$$

b) the mean value of the signals $V_{MA} \cdot \text{sign } V_{AB}$ and $V_{MB} \cdot \text{sign } V_{AA}$ is lower than the theoretical one because there is a shift in the phase of the signals V_{MA} and V_{MB} . The relative percentage error only due to the shift of the phase is

$$\epsilon_2 = (\cos \varphi - 1) \cdot 100 \quad \varphi = \text{tg}^{-1} \omega R5 C6$$

The total percentage decrease of the TACHO signal is given with a good approximation by the sum of ϵ_1 and ϵ_2 .

Example :

Consider :

$f = 3000\text{Hz}$ corresponding to

$$n = \frac{3000}{200} \cdot 60 = 900\text{rpm of the motor if 200 are the tracks/turn of the encoder}$$

$$\epsilon_1 \cong -2.6\% \text{ with } R5 = 820\Omega$$

$$C6 = 15\text{nF}$$

$$\epsilon_2 \cong -2.6\%$$

$$\epsilon_3 \cong \epsilon_1 + \epsilon_2 \cong -5.2\%$$

From the diagram of fig. 21 we note that at a speed of 900 rpm corresponds a theoretical speed of 855rpm with a percentage difference of about 5.2%.

SPEED ACCURACY DUE TO THE D/A CONVERTER

To analyse the influence of the DAC precision on the speed accuracy we will refer to the following (fig. 25).

Figure 25.

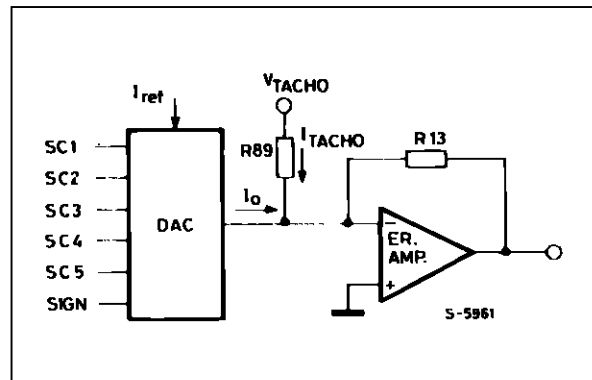

The value of the output current of the DAC I_o depends on I_{ref} and on the digital code defined by the inputs SC1-SC5, while its direction depends on the value of the SIGN input, the max theoretical value of I_o , obtained with SC1-SC5 low is :

$$I_{OM} = \pm \frac{31}{16} I_{ref}$$

The motor will run at a speed corresponding to the following value of the TACHO signal :

$$V_{TACHO} = - I_{OM} \cdot R89 = \pm \frac{31}{16} I_{ref} \cdot R89$$

This last relation is true if we don't consider the motor friction and the offsets. Consider now the possible friction and the offsets. Consider now the possible spreads we can have in the motor speed due to the DAC. If we call I_{OM1} the value of the max output current I_o corresponding to the SIGN LOW and I_{OM2} the one corresponding to the SIGN HIGH, the percentage error we have in the max speed from the positive to the negative value is :

$$\epsilon_4 = \frac{I_{OM1} + I_{OM2}}{I_{OM}} \cdot 100$$

Note that we have consider the sum of I_{OM1} and I_{OM2} because they have opposite signs. This kind of error is principally due to a different gain of the DAC between the two conditions of the SIGN LOW and HIGH. An equal difference of I_{OM1} and I_{OM2} , from I_{OM} ($|I_{OM1}| - |I_{OM}| = |I_{OM2}| - |I_{OM}|$) doesn't constitute a speed error because this shift from the theoretical value can be compensated by adjusting the resistor R89 that is formed by a fixed resistor in series with a potentiometer.

With the guaranteed values on the L291 data sheet we can calculate for ε_4 the max value :

$$\varepsilon_4 = \frac{21 \mu\text{A}}{1.4 \text{ mA}} \cdot 100 = 1.5 \%$$

Another characteristic of a D/AC is the linearity, that in our case is better than $\pm 1/2$ LSB. This value is sufficient to guarantee the monotonicity of I_b , and then of the speed of the motor, as a function of the input digital code. The precision of $\pm 1/2$ LSB implies a spread of the speed at every configuration of the input code of $\pm 1.61\%$ referred to the maximum speed. The max percentage error we can have is then greater at low level speed ($\pm 50\%$ at min speed) and has its minimum value at the maximum speed (1.61%).

ACCURACY DUE TO THE ENCODER

The amplitude of the signals FTA and FTB determines the value of the TACHO signal. This amplitude must be constant on the whole range of the frequency, otherwise it is not possible to have a linear function between the TACHO signal and the frequency. The spread of the amplitudes of the two signals FTA and FTB between several encoder can be compensated by adjusting the potentiometer R9 (see fig. 12). The phase between the two signals should be 90° . If there is a constant difference from this value, a constant factor reduction of the TACHO signal results that can be compensated with the potentiometer R9. If the difference from 90° is random, also the reduction of the TACHO signal is random in the same way, and by means of R9 it is possible to compensate only the mean value of that reduction.

APPLICATION NOTE

Information furnished is believed to be accurate and reliable. However, SGS-THOMSON Microelectronics assumes no responsibility for the consequences of use of such information nor for any infringement of patents or other rights of third parties which may result from its use. No license is granted by implication or otherwise under any patent or patent rights of SGS-THOMSON Microelectronics. Specifications mentioned in this publication are subject to change without notice. This publication supersedes and replaces all information previously supplied. SGS-THOMSON Microelectronics products are not authorized for use as critical components in life support devices or systems without express written approval of SGS-THOMSON Microelectronics.

© 1995 SGS-THOMSON Microelectronics - All Rights Reserved

SGS-THOMSON Microelectronics GROUP OF COMPANIES

Australia - Brazil - France - Germany - Hong Kong - Italy - Japan - Korea - Malaysia - Malta - Morocco - The Netherlands - Singapore - Spain - Sweden - Switzerland - Taiwan - Thailand - United Kingdom - U.S.A.